

NOTE: LOAD SHOULD BE EVENLY DISTRIBUTED BY POSITIONING THE CENTER OF GRAVITY DIRECTLY IN THE CENTER OF THE LIFTING BEAMS AS SHOWN IN THE ILLUSTRATION

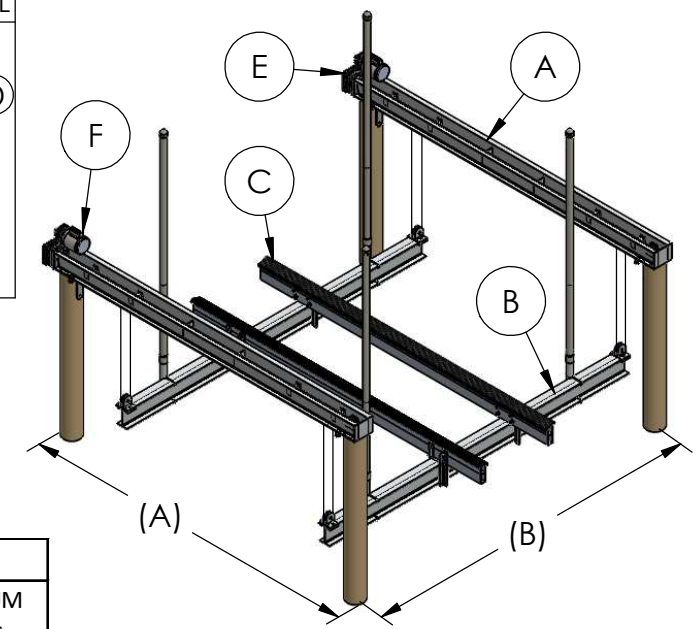

4 PILING BOAT LIFT SPECIFICATION SHEET

2018	TOP BEAM (A)	CRADLE BEAM (B)	BUNKS (C)	CABLE SIZE (D)	DRIVE (E)	H.P. MOTOR (F)	DRIVE SHAFT	MINIMUM PILING (SIZE & QTY.)	
5,000 LB.	5" CHANNEL X 12' 6"	4" X 6" X 10'	8" ALUM	5/16" SS 7/19 (.313) SINGLE PULL	DIRECT DRIVE	3/4 H.P. (QTY. 2) 220V 4.9A EACH	1-1/2" (SCH 40)	8" (QTY. 4)	
7,000 LB.	6" CHANNEL X 12' 6"	4" X 6" X 12' 6"				1 H.P. (QTY. 2) 220V 6.8A EACH			
10,000 LB.	7" CHANNEL X 12' 6"	5" X 8" X 12' 6"				3/4 H.P. (QTY. 2) 220V 4.9A EACH			
13,000 LB.			1 H.P. (QTY. 2) 220V 6.8A EACH						
16,000 LB.	8" CHANNEL X 12' 6"	6" X 10" X 14'	10" ALUM	5/16" SS 7/19 (.313) TRIPPLE PULL		3/4 H.P. (QTY. 2) 220V 4.9A EACH			10" (QTY. 4)
20,000 LB.	9" CHANNEL X 14' 6"	6" X 10" X 15'				1 H.P. (QTY. 2) 220V 6.8A EACH			
24,000 LB.		7" X 12" X 16'			1 H.P. (QTY. 2) 220V 6.8A EACH				

4 PILING BOAT LIFT PILING SPACING		
FOUR PILING LIFTS	(A) BOW TO STERN (OUTSIDES)	(B) PORT TO STARBOARD (CENTERS)
5,000 LB.	12 FT 6 IN	10 FT
7,000 LB.		12 FT 6 IN
10,000 LB.		
13,000 LB.	14 FT 6 IN	14 FT
16,000 LB.		15 FT
20,000 LB.	16 FT	
24,000 LB.		

TITLE:
5K-24K 4 POLE BOAT LIFT ENGINEERING SHEET

PH: 800-325-1116
 FAX: 252-747-4377
 TIDETAMER.COM
 P.O. BOX 1118
 SNOW HILL, NC 28580

ENGINEERING SEAL AFFIXED HERETO VALIDATES STRUCTURAL DESIGN AS SHOWN ONLY. USE OF THIS SPECIFICATION BY CONTRACTOR, et. al. IDEMNIFIES & SAVES HARMLESS THIS ENGINEER FOR ALL COST & DAMAGES INCLUDING LEGAL FEES & APPELLATE FEES RESULTING FROM MATERIAL FABRICATION, SYSTEM ERECTION & CONSTRUCTION PRACTICES BEYOND THAT WHICH IS CALLED FOR BY LOCAL, STATE, & FEDERAL CODES & FORM DEVIATIONS OF THIS PLAN, EXCEPT AS EXPRESSLY PROVIDED IN HEREIN, NO CERTIFICATION OR AFFIRMATIONS ARE INTENDED. PAUL WELCH, INC. HAS NOT VISITED THIS JOB SITE. INFORMATION CONTAINED HEREIN IS BASED ON CONTRACTOR SUPPLIED DATA AND MEASUREMENTS. PAUL WELCH, INC. SHALL NOT BE HELD RESPONSIBLE OR LIABLE IN ANY WAY FOR ERRONEOUS OR INACCURATE DATA OR MEASUREMENTS. WORK SHALL BE VERIFIED PRIOR TO CONSTRUCTION. PAUL WELCH, INC. SHALL BE NOTIFIED AND GIVEN AN OPPORTUNITY TO REEVALUATE OUR WORK UPON DISCOVERY OF ANY INACCURATE INFORMATION PRIOR TO MODIFICATION OF EXISTING FIELD CONDITIONS AND FABRICATION AND INSTALLATION OF MATERIALS.

PROPRIETARY AND CONFIDENTIAL
 THE INFORMATION CONTAINED IN THIS DRAWING IS THE SOLE PROPERTY OF TIDE TAMER INDUSTRIES. ANY REPRODUCTION IN PART OR AS A WHOLE WITHOUT THE WRITTEN PERMISSION OF TIDE TAMER INDUSTRIES IS PROHIBITED.

ENGINEERS SEAL

SIZE	DWG. NO.	REV
A	ENGINEERING	1
SCALE: AS NOTED	DRAWN BY: ACC	DATE: 12-6-18
SHEET 1 OF 1		